

XPS

Surge Arrester - System Voltage 2 kV to 245 kV



ABB

Metal Oxide Surge Arrester XPS



Protection of switchgear, transformers and other equipment in high voltage systems against atmospheric and switching overvoltages. For use when requirements of lightning intensity, energy capability and pollution are moderate.

Superior design where low weight, reduced clearances, flexible mounting, and shatter-proof housing is required.

Application

The XPS polymer arrester has been verified to meet station class requirements of ANSI C62.11 (IEEE Standard for Metal-Oxide Surge Arresters for AC Power Circuits). The XPS arrester is designed to meet the following performance data:

Performance data

Maximum system voltages (V_M)	2.52 - 245 kV _{rms}
Duty cycle rated voltages (V_T)	3 - 240 kV _{rms}
Classifying current (ANSI/IEEE)	10 kA _{peak}
Discharge current withstand strength:	
High current 4/10 μ s	100 kA _{peak}
Low current 2000 μ s	900 A _{peak}
Energy capability:	
2 impulses, (IEC Cl. 7.5.5)	9.8 kJ / kV of MCOV
Fulfills requirements of ANSI transmission-line discharge test for 245 kV systems	
Short-circuit / Pressure relief capability	80 kA rms sym
Cantilever strength	20000 in - lbs / 2260 Nm
Service conditions:	
Ambient temperature	-50°C to + 45 °C
Design altitude	6000 ft / 1830 m
Frequency	15 - 62 Hz

1) Higher strength designs available on request

2) Higher altitude designs available on request

Direct-Molded Construction

ABB's type XPS surge arrester consists of high performance metal oxide disks molded in a shatter-proof polymer housing. The XPS now has a new construction to enhance overall lifetime performance.

The metal oxide disks are enclosed in a support assembly consisting of reinforced epoxy/fiberglass loops connecting the upper and lower aluminum end pieces. The silicone polymer material is then molded directly to the metal oxide loop assembly eliminating any air pockets which could cause moisture ingress over time.

Each arrester is furnished with a mounting base for an 8.75 in / 222 mm to 10.0 in / 254 mm diameter bolt circle along with 4-hole NEMA pad, line and ground terminals for electrical connections.

100% Silicone Based Housing

The silicone rubber housing features high tracking and arc resistance, excellent hydrophobic properties, and resistance to weathering, UV radiation and pollution.

Benefits

The incorporation of polymer material in a station class surge arrester has resulted in many additional advantages. Among these are:

Reduced Electrical Clearance

Polymer construction has resulted in much smaller housing dimensions in comparison with porcelain units of the same voltage rating. This size reduction enables efficient use of space for switchgear enclosures, mobile substations and other applications where space restrictions are present.

Lightweight

The type XPS arrester is less than 50 percent the weight of its porcelain counterpart, which results in easier handling and installation.

Damage Resistant

Polymer construction reduces possible shipping and handling damage, as well as, damage due to vandalism.

Safety

Shatter-resistant construction provides greater protection for personnel, as well as, nearby equipment.

Nameplate

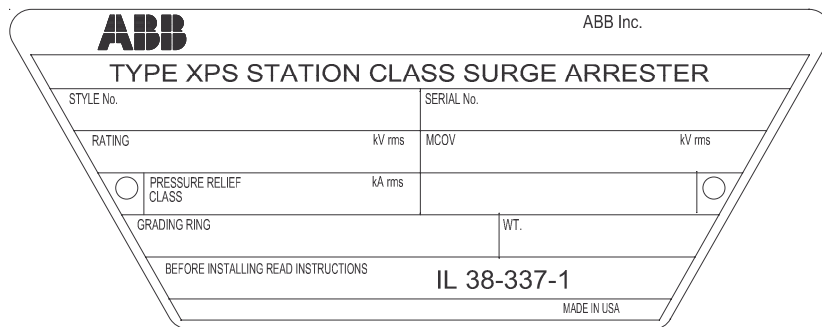

Guaranteed Performance Data

Power frequency voltage, kV rms						Maximum residual voltage with current wave, kV peak						
Nom. V _n (1)	Max. V _m (2)	Rating V _r (3)	MCOV (4)	TOV (5)		SPL (6) 30/60 μs	LPL (7) 8/20 μs				FOW (8) 0.5 μs 10 kA	
				1 s	10 s		3 kA	5 kA	10 kA	20 kA		40 kA
2.40	2.52	3	2.55	5.26	5.04	9.27	10.4	10.8	11.3	12.5	13.9	12.3
4.16	4.37	3	2.55	5.26	5.04	9.27	10.4	10.8	11.3	12.5	13.9	12.3
4.16	4.37	6	5.10	7.17	6.84	12.3	13.8	14.3	15.0	16.5	18.5	17.1
4.80	5.04	6	5.10	7.17	6.84	12.3	13.8	14.3	15.0	16.5	18.5	17.1
6.90	7.24	6	5.10	7.17	6.84	12.3	13.8	14.3	15.0	16.5	18.5	17.1
6.90	7.24	9	7.65	10.5	10.0	18.6	20.8	21.5	22.6	24.9	27.8	24.5
6.90	7.24	10	8.40	11.7	11.2	20.4	24.4	25.2	25.0	29.2	32.6	28.7
8.32	8.73	6	5.10	7.17	6.84	12.3	13.8	14.3	15.0	16.5	18.5	17.1
8.32	8.73	9	7.65	10.7	10.2	18.5	20.8	21.5	22.6	24.9	27.8	24.4
8.32	8.73	10	8.40	11.9	11.4	20.4	23.0	23.8	25.0	27.5	30.8	27.0
8.32	8.73	12	10.2	14.0	13.4	24.6	27.6	28.5	30.0	32.9	36.9	34.2
12.0	12.6	9	7.65	10.7	10.2	18.5	20.8	21.5	22.6	24.9	27.8	24.4
12.0	12.6	10	8.40	11.9	11.4	20.4	23.0	23.8	25.0	27.5	30.8	27.0
12.0	12.6	12	10.2	14.3	13.6	24.6	27.6	28.5	30.0	32.9	36.9	34.2
12.0	12.6	15	12.7	17.5	16.8	30.7	34.5	35.9	37.5	41.3	46.2	40.5
12.47	13.10	9	7.65	10.7	10.2	18.5	20.8	21.5	22.6	24.9	27.8	24.4
12.47	13.10	10	8.40	11.9	11.4	20.4	23.0	23.8	25.0	27.5	30.8	27.0
12.47	13.10	12	10.2	14.3	13.6	24.6	27.6	28.5	30.0	32.9	36.9	34.2
12.47	13.10	15	12.7	17.9	17.1	30.7	34.5	35.6	37.5	41.3	46.1	40.5
12.47	13.10	18	15.3	21.5	20.5	36.9	41.4	42.8	45.0	49.3	55.4	51.3
13.2	13.9	10	8.40	11.9	11.4	20.4	23.0	23.8	25.0	27.5	30.8	27.0
13.8	14.5	12	10.2	14.3	13.6	24.6	27.6	28.5	30.0	32.9	36.9	34.2
13.8	14.5	15	12.7	17.9	17.1	30.7	34.5	35.6	37.5	41.3	46.1	40.5
13.8	14.5	18	15.3	21.5	20.5	36.9	41.4	42.8	45.0	49.3	55.4	51.3
20.78	21.8	15	12.7	17.9	17.1	30.7	34.5	35.6	37.5	41.3	46.1	40.5
20.78	21.8	18	15.3	21.5	20.5	36.9	41.4	42.8	45.0	49.3	55.4	51.3
20.78	21.8	21	17.0	24.5	23.5	41.4	46.4	48.2	50.4	55.5	62.0	54.7
20.78	21.8	24	19.5	27.6	26.4	47.1	52.9	54.7	57.6	63.4	70.8	62.2
20.78	21.8	27	22.0	31.5	30.2	53.2	59.7	61.9	64.8	71.3	79.8	70.4
22.86	24.00	18	15.3	21.5	20.5	36.9	41.4	42.8	45.0	49.3	55.4	51.3
23.00	24.15	21	17.0	25.0	23.9	41.4	46.4	48.2	50.4	55.5	62.0	54.7
23.00	24.15	24	19.5	27.6	26.4	47.1	52.9	54.7	57.6	63.4	70.8	62.2
23.00	24.15	27	22.0	31.5	30.2	53.2	59.7	61.9	64.8	71.3	79.8	70.4
23.00	24.15	30	24.4	35.1	33.6	59.1	66.3	68.4	72.0	79.2	88.6	77.8
24.94	26.19	18	15.3	21.5	20.5	36.9	41.4	42.8	45.0	49.3	55.4	51.3
24.94	26.19	21	17.0	25.0	23.9	41.4	46.4	48.2	50.4	55.5	62.0	54.7
24.94	26.19	24	19.5	27.6	26.4	47.4	52.9	54.7	57.6	63.4	70.8	62.2
24.94	26.19	27	22.0	31.5	30.2	53.2	59.7	61.9	64.8	71.3	79.8	70.4
24.94	26.19	30	24.4	35.8	34.2	59.1	66.3	68.8	72.0	79.2	88.6	78.2
24.94	26.19	36	29.0	41.4	39.6	70.9	79.5	82.1	86.4	95.1	107	93.4
34.5	36.2	27	22.0	31.5	30.2	53.2	59.7	61.9	64.8	71.3	79.8	70.4
34.5	36.2	30	24.4	35.8	34.2	59.1	66.3	68.8	72.0	79.2	88.6	78.2
34.5	36.2	36	29.0	41.4	39.6	70.9	79.5	82.6	86.4	95.1	107	93.4
34.5	36.2	39	31.5	44.8	42.9	76.8	86.2	89.0	93.6	103	116	102
34.5	36.2	45	36.5	52.6	50.4	88.6	99.4	103	108	119	133	117
46.0	48.3	36	29.0	41.4	39.6	70.9	79.5	82.6	86.4	95.1	107	93.4
46.0	48.3	39	31.5	44.8	42.9	76.8	86.2	89.4	93.6	103	116	102

Power frequency voltage, kV rms						Maximum residual voltage with current wave, kV peak						
Nom. V _n (1)	Max. V _m (2)	Rating V _r (3)	MCOV (4)	TOV (5)		SPL (6) 30/60 μs	LPL (7) 8/20 μs					FOW (8) 0.5 μs 10 kA
				1 s	10 s		3 kA	5 kA	10 kA	20 kA	40 kA	
46.0	48.3	45	36.5	53.7	51.3	88.6	99.4	104	108	119	133	118
46.0	48.3	48	39	56.1	53.7	94.5	106	110	116	127	142	126
46.0	48.3	54	42	63.1	60.4	107	120	124	130	143	160	140
46.0	48.3	60	48	70.2	67.2	119	133	137	144	159	178	156
46.0	48.3	72	57	84.2	80.6	142	161	167	174	191	215	189
69	72.5	54	42	64.5	61.5	107	120	124	130	143	160	140
69	72.5	60	48	71.7	68.4	119	133	138	144	159	178	157
69	72.5	72	57	86.0	82.0	139	161	167	174	191	215	189
69	72.5	90	70	105	100	178	199	206	216	238	266	234
69	72.5	96	76	112	107	189	212	219	231	254	284	249
115	123	90	70	107	102	173	199	207	216	238	266	235
115	123	96	76	114	109	189	213	221	231	255	285	251
115	123	108	84	124	118	220	239	247	260	286	319	281
115	123	110	88	126	121	225	252	262	274	302	336	296
115	123	120	98	138	132	244	265	274	288	317	355	311
115	123	132	106	154	147	261	292	301	317	349	390	343
115	123	144	115	165	161	293	318	329	346	381	426	374
138	145	108	84	124	118	220	239	247	260	286	319	281
138	145	110	88	126	121	225	252	262	274	302	336	296
138	145	120	98	138	132	244	265	276	288	317	355	311
138	145	132	106	157	150	261	292	303	317	349	390	344
138	145	144	115	165	164	293	319	331	346	381	426	374
138	145	168	131	200	191	332	364	376	404	435	486	427
161	170	132	106	157	150	251	292	303	317	349	390	344
161	170	144	115	165	164	293	319	331	346	381	426	374
161	170	168	131	196	188	332	371	384	404	444	496	436
161	170	172	140	203	194	351	385	397	418	460	514	452
161	170	180	144	210	201	363	398	411	432	476	532	467
161	170	192	152	221	211	388	424	438	461	507	567	498
230	245	180	144	215	205	363	398	411	432	476	532	467
230	245	192	152	221	211	388	424	438	461	507	567	498
230	245	216	173	248	237	437	477	495	518	570	637	560
230	245	228	180	266	255	460	504	520	548	602	674	591
230	245	240	190	280	268	484	530	548	576	634	709	623

- (1) V_n = Nominal System Voltage per ANSI C84.1
- (2) V_m = Maximum System Voltage per ANSI C84.1
- (3) V_r = Duty Cycle Rated Voltage per ANSI C62.11
- (4) MCOV = Maximum Continuous Operating Voltage per ANSI C62.11
- (5) TOV = Temporary Overvoltage with No Prior Energy

- (6) SPL = Switching Protective Level
500 A 3 - 132 kV
1,000 A 144 - 240 kV
- (7) LPL = Lightning Protective Level
- (8) FOW = Front of Wave

Technical data for housings

Rating V _r	Style No.	Height H		Creepage		Weight		Phase to Ground S		Phase to Phase T		Figure
		in	mm	in	mm	lb	kg	in	mm	in	mm	
3	Q003SA002A	13.5	351	11.2	284	18	8.2	7	178	11	279	1
6	Q006SA005A	13.5	351	11.2	284	18	8.2	7	178	11	279	1
9	Q009SA008A	17.4	450	23.6	599	22	10	7	178	11	279	1
10	Q010SA008A	17.4	450	23.6	599	22	10	7	178	11	279	1
12	Q012SA010A	17.4	450	23.6	599	22	10	7	178	11	279	1
15	Q015SA012A	17.4	450	23.6	599	22	10	7	178	11	279	1
18	Q018SA015A	17.4	450	23.6	599	22	10	8	203	12	305	1
21	Q021SA017A	23.3	592	42.0	1067	33	15	9	228	13	330	1
24	Q024SA019A	23.3	592	42.0	1067	33	15	10	254	14	355	1
27	Q027SA022A	23.3	592	42.0	1067	33	15	11	279	15	381	1
30	Q030SA024A	23.3	592	42.0	1067	33	15	12	305	16	406	1
36	Q036SA029A	23.3	592	42.0	1067	33	15	13	330	17	432	1
39	Q039SA031A	31.2	793	66.7	1694	47	21	14	355	18	457	1
45	Q045SA037A	31.2	793	66.7	1694	47	21	15	381	19	483	1
48	Q048SA039A	31.2	793	66.7	1694	47	21	16	406	19	483	1
54	Q054SA042A	31.2	793	66.7	1694	47	21	17	432	20	508	1
60	Q060SA048A	31.2	793	66.7	1694	47	21	18	457	21	533	1
72	Q072SA057A	41.7	1059	84.0	2133	60	27	20	508	23	584	2
90	Q090SA070A	49.6	1260	108	2760	74	33	23	584	26	560	2
96	Q096SA076B	49.6	1260	108	2760	74	33	25	635	27	586	2
108	Q108SA084B	58.5	1486	133	3388	93	42	39	990	51	1295	3
110	Q110SA088B	58.5	1486	133	3388	93	42	40	1016	52	1321	3
120	Q120SA098B	58.5	1486	133	3388	93	42	43	1092	55	1397	3
132	Q132SA106B	68.7	1745	150	3832	110	50	46	1168	58	1473	4
144	Q144SA115B	76.6	1946	175	4457	123	56	50	1270	62	1575	4
168	Q168SA131B	84.5	2146	200	5082	137	62	62	1575	78	1981	5
172	Q172SA140B	84.5	2146	200	5082	139	63	63	1600	79	2006	5
180	Q180SA144B	84.5	2146	200	5082	139	63	65	1651	81	2057	5
192	Q192SA152B	94.7	2405	217	5527	154	70	69	1753	85	2159	6
216	Q216SA173B	103	2606	242	6151	169	77	76	1930	92	2336	6
228	Q228SA180B	110	2807	266	6776	183	83	80	2032	96	2438	6
240	Q240SA190B	110	2807	266	6776	183	83	84	2133	100	2540	6

- 1) Increase clearances "S" and "T", 3% per each 1000 ft over 6000 ft / 305 m over 1830 m
- 2) Arrester assembly consists of arrester unit, line, ground terminals and grading rings for ratings 108 kV and above
- 3) Minimum dimensions for arresters, other apparatus standards and other specifications or local codes may require greater spacing
- 4) Mounting slots for 0.50 in / 12.7 mm diameter hardware, three equally spaced on 8.75 in / 222.25 mm to 10.0 in / 254 mm bolt circle, thickness of lug 0.25 in / 6 mm

Standard Hardware

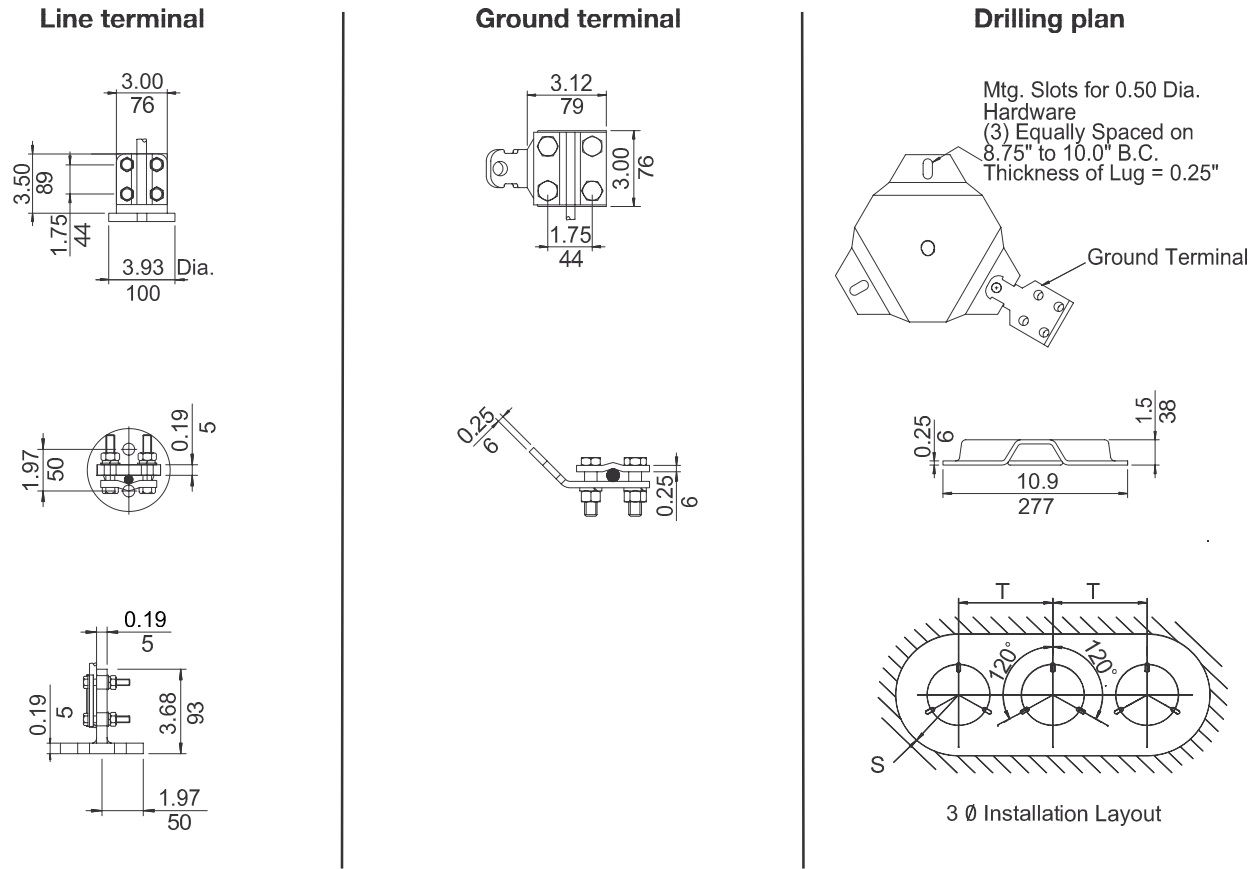

1) Line and ground terminals can accommodate copper or aluminum cable size Number 2 to 1000 MCM / 0.25 to 1.19 in / 6 to 30 mm diameter. Ground terminal can be located on any lug.

Outlines

